

MAESTRO DLH 1186 T

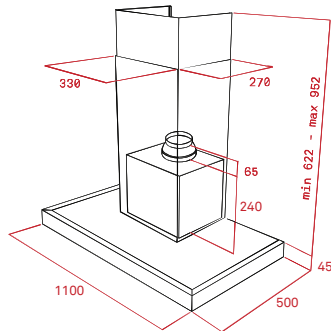

Ultraslim decorative hood

Eco power

Double turbine armored motor EcoPower
Power Rating: A +
Touch Control digital controls with white display
3 speeds + intensive
Selected speed digital indicator
Aspiration timer
Filter saturation indicator light
Non-Return Valve
Extraction capacities (*):
min. 303 m³ / h
max. 701 m³ / h
Sound power (*):
min. 53 dBA
max. 69 dBA

LED Lighting Bar

Stainless steel decorative filters

Possibility of operation in recirculation

(* Delegated Regulation (EU) No 65/2014 of the Commission of 1 October 2013.

External Dimensions

➔ W 1100 mm

