

DPL ISLA 1180



LED



Perimeter
extraction



Stop Delay
Timer

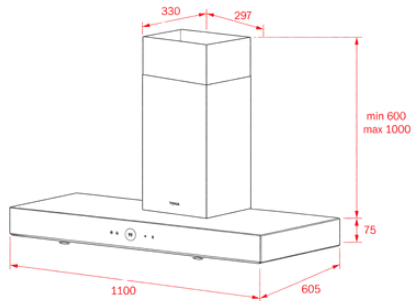

TEKA

110 cm decorative island hood with digital Touch Control and white display

Digital controls

Touch Control with white display

Perimeter extraction

3 speeds + intensive

Delay timer

4 LED lamps

Stainless steel movable panel with aluminium filter

Filter saturation indicator

150/120 reduction included

Double turbine motor

Extraction capacity: 1200 m³/h

Sound power: min. 45 dBA – max. 65 dBA

Recirculation kit: SET 1/T1

Black glass and stainless steel finish

External Dimension

- ↑ H 817 - 1117 mm
- W 1100 mm
- ↗ D 605 mm

