

## DVU 590



LED



Perimeter  
extraction



Stop Delay  
Timer

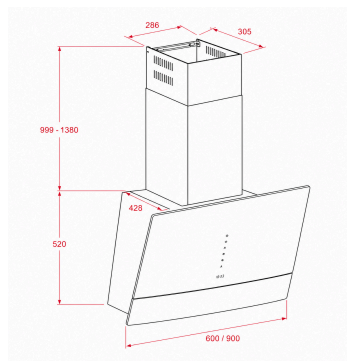

**TEKA**

### **90 cm decorative wall-mounted hood in black glass and stainless steel**

Touch Control with white display

Double turbine motor

Automatic opening

Energy efficiency class D

3 speeds

2 LED lamps

Maximum extraction capacity: 538 m<sup>3</sup>/h

Sound power: 50 – 59 dBA

Metal filters

Optional active charcoal filters: D6C

Wall-mounted installation

Black glass finish

---

### **External Dimension**

- ↑ H 900 mm
- W 520 mm
- ↗ D 428 mm

