

IN TSZ 1612 UK

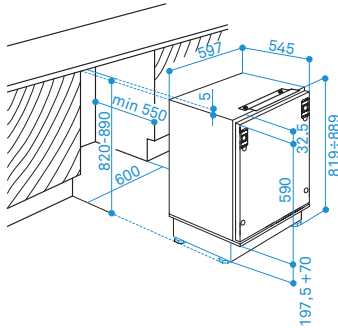

Built-in fridge

Mechanical control panel

Manual defrost

Safety glass shelves

Door on door installation

Reversible door

Energy Class : A++

Climate Class : SN-T

Noise level : 40 dBA

Total gross capacity : 130 liters

Net capacity (fridge) : 126 liters

Voltage : 230/50 Hz

External Dimensions

- H 820 mm
- W 598 mm
- D 545 mm

PURE WIND IN THE FRIDGE

Indesit fridges offer a great way to preserve moisture and prevent drying of foods thanks to the improved air circulation inside the fridge cavity. Pure Wind is the ventilation system specifically designed for the fridge able to cool the air through the action of the fan located on the rear wall of the fridge, keeping even temperature throughout the compartment

