

# MLE21PNAGW

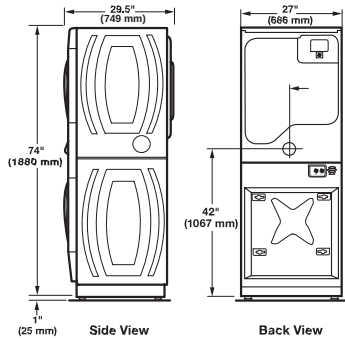

## LEGENDARY MAYTAG DEPENDABILITY

Maximizing your equipment investment for over a half century.

## A COMPLETE LINE OF ENERGY-EFFICIENT SOLUTIONS

Maytag brand offers a complete line of high-efficiency commercial laundry appliances from energy-efficient dryers to highly efficient ENERGY STAR® qualified washers to help you save money and build profits.

## MICROPROCESSOR CONTROLS

Maytag® Computer Trac controls are easy to program and operate. Plus, they give owners the flexibility to set vend prices by day, time, water temperature and Super Cycle options.

## SAVE SPACE AND CUT UTILITY COSTS

A Maytag® commercial stack washer/dryer gives you a full-size high-efficiency washer and a super-capacity dryer in the space of a washer alone.

## FOR CUSTOMERS:

- Large Capacity For Bulky Items 3.1-cu.-ft. Capacity Washer/ 6.7-cu.-ft. Capacity Dryer
- High-Speed Extraction Cuts Drying Time (up to 1,000 RPMs)
- 180° Door Opening With Heavy-Duty Die-Cast Hinge
- Display Panel Angled For Easy Viewing
- Easy-To-Use, One-Touch Cycle Selection
- Quick Cycle Reduces Total Wash Time

## BUILT-TO-LAST™ FEATURES:

- Precision Endurance Drive
- 5-Year Limited Warranty All Parts Covered

## External Dimensions

- ⓘ H 1905 mm
- ↻ W 686 mm
- ↻ D 749 mm

