

# FRANKE

## TALE 1215 W XS

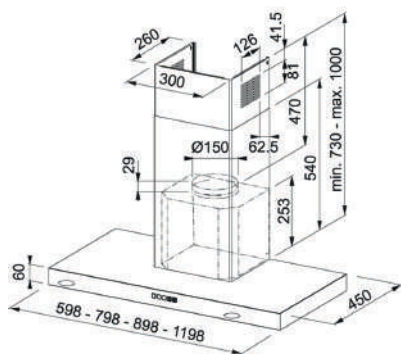

### Decorative Hood

3 Speed + Intensive  
Energy Motor  
Filter saturation indicator  
Grease filter efficiency class B  
Energy rating: A ++  
m<sup>3</sup> / h max (IEC 61591): 400  
m<sup>3</sup> / h Int. (IEC 61591): 740 m<sup>3</sup> / h  
Max noise level (dbA): 62  
Int. Noise level (dbA): 70 dBA  
Wattage (W): 250 W  
Total power: 270-W  
Pressure (Pa): 520.00 Pa  
Lighting: LEDS-4X1W  
Power cable length: 150 mm

### External Dimensions

➔ W 1200 mm

