

**TL 6310**

**TEKA**

**60 cm pull-out hood with double turbine motor and 2 speeds**

Pull-out hood

Mechanical control

2 speeds

Double turbine motor

Free outlet extraction capacity: 366 m<sup>3</sup>/h

Maximum extraction capacity: 332 m<sup>3</sup>/h

Minimum extraction capacity: 233 m<sup>3</sup>/h

Maximum sound level: 54 dBA

Minimum sound level: 45 dBA

2 LED lamps

2 aluminium filters

Exchangeable front panel

Anti-return valve included

Optional charcoal filter: CNL 1C

Stainless steel finish

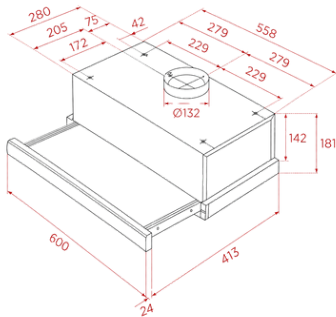

**External Dimension**

- ↑ H 184 mm
- W 600 mm
- ↗ D 280–437 mm

