

# Miele

## CS 1212-1 I

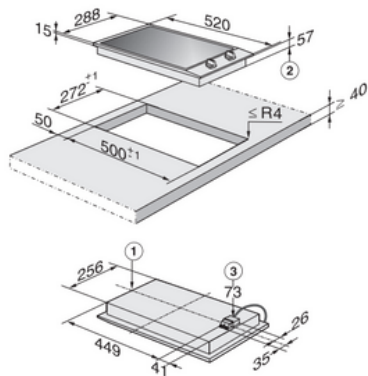

### ProLine element with two induction-heated cooking zones

Heating type: Induction.  
Elegant glass ceramic surface.  
Stainless steel frame.  
Print design: LightPrint.  
Miele logo embossed in stainless steel.  
Surface-mounted installation.  
Pan and pan size recognition.  
Auto heat-up.  
Keeping warm.  
Operation via knobs.  
Residual heat utilisation.  
Easy to clean ceramic glass.  
Safety switch-off.  
Lock function.  
System lock.  
Integrated cooling fan.  
Overheating protection.  
Residual heat indicator.  
Operational indicator.  
Number of cooking zones 2.  
Position front centre Type Dual-circuit ring.  
Size in mm  $\varnothing$  100-160.  
Max. Booster power rating in W 2200 Max. rating in W 1400.  
Position rear centre Type Dual-circuit ring.  
Size in mm  $\varnothing$  160-230.  
Max. Booster power rating in W 3000 Max. rating in W 2300 Max.  
TwinBooster power rating in W 3700

### External Dimensions

- ① H 900 mm
- ➔ W 288 mm
- ② D 520 mm

